

ECOWATER  
SYSTEMS®



Your Water. Perfected.

Let us

Perfect  
your water and

Maximize  
your peace of mind.

## ESS1152

ECOWATER 1100 SERIES WATER SOFTENER

### Enjoy Cleaner, Softer Water Throughout Your Home

- 1 Electronic Timer**  
Electronic timer controls regeneration frequency. Full menu-driven options.  
**Six-Cycle Valve with Easy-Clamp Ring and Patented Coated Discs**
- 2 Multi-Wrap Fiberglass Reinforced Resin Tank**  
Durable fiberglass-wrapped tank liner, doesn't deteriorate, rust, or corrode.
- 3 Self-Cleaning Distributors**  
Distributors exhibit excellent flow rates and are cleaned automatically by preventing clogging.
- 4 Brine Valve**  
Controls water flow in and out of salt tank. Features automatic shut-off to prevent overfilling.  
**Ability to Choose Media for Custom Applications**  
Ships without media to give flexibility in providing solutions for different problem water situations.  
**Energy Efficient Power Supply**  
Simplifies installation, maintenance and reduces electrical hazards.



 Designed, Engineered &  
Assembled in the U.S.A.

ecowater.com

# ESS1152

ECOWATER 1100 SERIES  
WATER SOFTENER

## DIMENSIONS

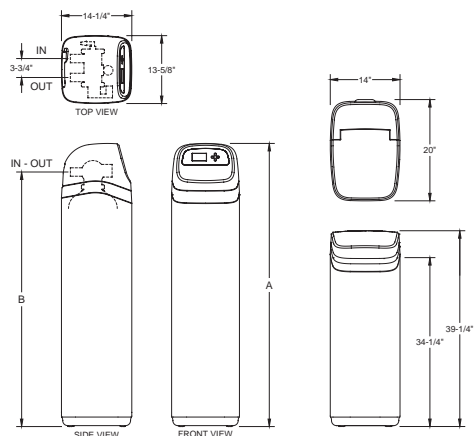

	ESS1152 R32
Nominal Resin Tank Size	10" Diam. x 47"
A	49 <sup>3</sup> / <sub>4</sub> "
B	56 <sup>5</sup> / <sub>8</sub> "

## SPECIFICATIONS

### ESS1152R32

Supply Water Pressure Limits (psi) <sup>1</sup>	20-125
Supply Water Temperature Limits (°F/C°)	40-100 / 4-38
Service Flow Rate (gpm) <sup>2</sup>	9
Approximate Water Used Each Regeneration (gal.) <sup>3</sup>	41
Salt Storage Capacity (lbs.)	300
Electrical Requirement, 120V, 50/60Hz, (24V DC, 500 mA, power supply included)	

<sup>1</sup>Maximum pressure for Canadian use is 7.0 kg/cm<sup>2</sup>.

<sup>2</sup>Not to exceed 15 psi pressure loss

<sup>3</sup>When operated at 35 psi water pressure

## WARRANTY

- For the lifetime of the original owner, the mineral tank will not rust, corrode, leak, burst, or in any other manner fail to perform its proper function.
- For a period of ten years, the salt tank will be free of defects in materials and workmanship and will perform its proper function.
- For a period of three years, the valve body, electronic faceplate and all other parts will be free of defects in materials and workmanship and will perform their normal functions.

**ECOWATER**  
SYSTEMS®



Your Water. Perfected.

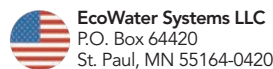

EcoWater Systems LLC  
P.O. Box 64420  
St. Paul, MN 55164-0420



EcoWater Canada Ltd.  
5240 Bradco Blvd.  
Mississauga, Ontario  
Canada L4W 1G7